

Technical Bulletin

Bulletin No 1. v3 – Updated August 2014

Fixing of AlumiGard™ and AlumiGard X™ as per MRM Code of Practice v3

This Bulletin follows the guidelines as laid down in the NZ Metal Roof and Wall Cladding Code of Practice Version 3.0

Aluminium has been used as a roofing material for many years and it performs well in Severe and Very Severe Marine, Geothermal and Industrial environments. As with any material, to achieve its potential durability installation requirements must be adhered to.

In general, good aluminium cladding design prevents salt laden air from entering the roof under-space, allows for adequate ventilation of the under-surface and prevents contact with dissimilar metals and corrosive surfaces.

Recommendations:

1. The front edge of the spouting or gutter must be higher than the crest of the roofing profile.
2. An eaves flashing of aluminium must be used. Underlay should terminate on the top of the eaves flashing.
3. In exposed situations, profiled closures of closed cell foam may be used at the eaves line. If closed cell foam is used, provision must be made for eaves or soffit ventilation, in addition to ventilation at the apex, to prevent structural damage due to excessive condensation build up.
4. When re-roofing with aluminium, the existing support members must be inspected to ensure that complete removal of staples, wire netting, nails or other materials likely to damage the aluminium have been removed.
5. Galvanised netting or mesh must not be in contact with the underside of aluminium roofs. If present, it must be separated by a 5mm barrier of inert non-absorbent, non-reactive material. Alternatively, self supporting underlays may be used. Plastic strapping can be used for supporting underlays, stapled with stainless steel staples to the vertical face of the purlins.
6. When aluminium is adjacent to a corrosive surface such as concrete, butyl rubber or CCA treated timber in a wet environment, separation must be achieved with a 5mm rigid strip of inert non-absorbent material, an open woven geo textile layer or PVC netting. Plastic coated steel netting is not recommended under aluminium sheeting.
7. All screws should be fitted with a profiled or bonded washer. Fixing screws shall be aluminium or stainless steel grade 304. When using stainless screws, they are to be fitted centrally through pre-drilled 9mm oversized holes for roofing and walls regardless of sheet length. For sheet lengths in excess of 10 metres, capacity to allow for thermal expansion must be in accordance with MRM v3.0 tables.

See overleaf for diagram of correct fixing methods

Self supported underlay
or underlay on plastic
strapping

Aluminium or stainless steel
fastener with washer fitted
through 9mm clearance hole

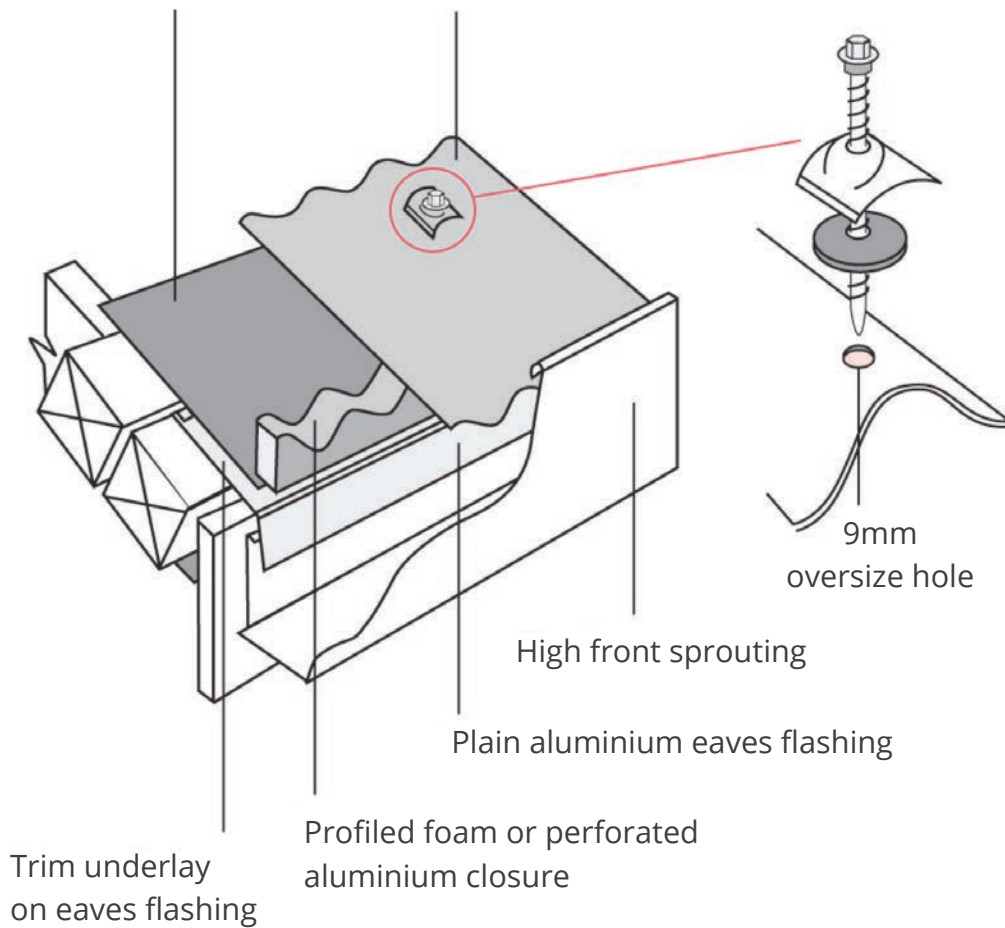

For further assistance contact Pacific Coilcoaters on 0800 279 979,
by email on enquiries@colorcote.co.nz or visit www.colorcote.co.nz.